









COFFEE MACHINE 30"

**FCM 4500 TF X
F6PTK30BC**



-  Touch Control
-  LED lighting
-  Boiling Water
-  Coffee Beans Grinder
-  Cappuccino Maker
-  Cleaning Program
-  Push Opening

COFFEE MACHINE

FEATURES

TFT touch display
Coffee grinder
Coffee container (200 g)
1 1.8 l water container.
Ground coffee container
Removable dispenser for boiling water and milk for cappuccino
Steam dispenser
Liquid collection basin
Opening with telescopic guides

SAFETY

Adjustment for water hardness
Warning light for no water, no coffee
Cleaning cycle request light
Limescale filter replacement warning light

PERFORMANCE

30 Automatic programs
3 Coffee temperatures
Simultaneous alternating preparation, 2 cups for 5 types of coffee (Extra strong, strong, medium, light, very light)
5 types of cups (Espresso, short, medium, large, jug)
Cappuccinatore
Steam delivery
Hot water supply (tea, infusions, herbal teas)
Stand-by (energy saving)

INCLUDED ACCESSORIES

Milk container
Telescopic racks
Power cable with plug



NOTE:

The Fulgor Milano badge is included in the Pro Frame Kit. Its installation / position is at the customer's discretion.

Coffee machine and Frame Pro Kit are sold separately with the following codes:

STAINLESS STEEL
FCM 4500 TF X
F6PTK30BC

FCM 4500 TF X
F6PTK30BC

Coffee Machine
Pro Frame Kit

PROFESSIONAL

COFFEE MACHINE

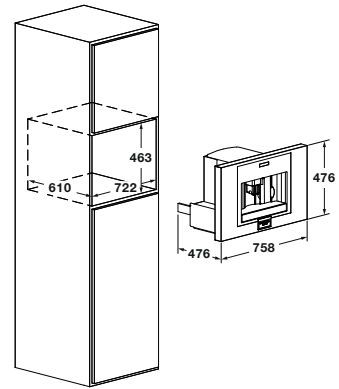

FCM 4500 TF X + F6PTK30BC	
Type	Coffee Machine
Finishing	Stainless steel Trim Kit
PERFORMANCE	
Total functions n.	30
Automatic functions	Coffee, steam, boiling water
Programming	Full Touch TFT
Energy efficiency	A
Annual energy consumption kWh	45
Water tank capacity	1,8 L
Coffee container capacity	200 g
Coffee grinder with 13 levels adjustment	•
Coffee cups n.	2
Height-adjustable coffee dispenser 80-100 mm	•
Retractable dispenser for steam and hot water	•
Compartment LED lighting	•
Automatic descaling program	•
Integrated cleaning program	•
0.75 L milk container	•
Drip tray	•
Limescale filter warning light	•
Residual emptying warning light	•
Water reserve warning light	•
POWER RATING	
Max electrical power (W)	1350 W
Voltage / Frequency (V - Hz)	220 - 240 / 50 - 60
Power cord	•
Plug	Schuko
Pump pressure (bar)	15
DIMENSIONS	
Width mm	758
Height mm	476
Depth mm	476
Cut-out (W x H x D) mm	722 x 463 x 610